

AG Shelter Series

Run-In Shed 22 x 20 x 11 ft. / 6,7 x 6,1 x 3,2 m



Delivers Shade & Protection. Instant Equine Shelter.

- Our Equine Run-In-Sheds are constructed using high grade heat treated steel. Every frame tube and connector goes through a proprietary steel surface preparation process.
- Professional grade 2-3/8 in. / 6 cm outside diameter all steel frame, bonded with a premium powder-coated finish resists chipping, peeling, rust and corrosion.
- Advanced engineered, 3-layer, chemically heat bonded, enhanced polyethylene, rip-stop fabric cover is standard issue. Hot air fused seams are 100% waterproof. UV-treated inside and out with added fade blockers, anti-aging, anti-fungal agents resulting in a cover that withstands the elements. High profile white interior lining provides enhanced illumination.
- Slip fit connectors and swedged tubing make for easy assembly. Bolt hardware at every connection ensures a solid structure.
- Heavy duty corner braces on corner ribs and rugged Ratchet Tite™ tensioning enables quick cover installation. Easy Slide Cross Rail system lock down and square up frames and bolt hardware for every connection point.
- Fabric corner boots protect livestock from ratchets and tie-downs.

Great For: Horses, hay, storage, livestock & farm equipment.

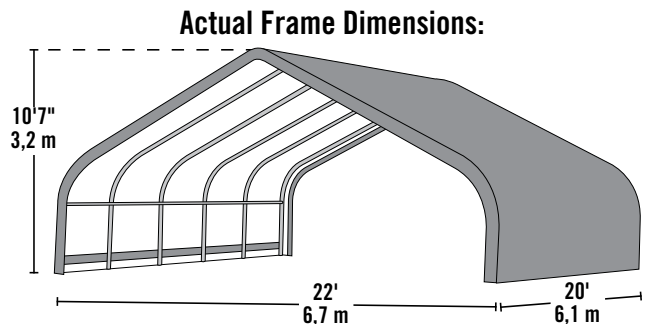

We've Got You Covered.™
North America's #1 Shelter Manufacturer.

Model #58432

Package Includes:

- (1) 22 x 20 x 10ft.7in. / 6,7 x 6,1 x 3,2 m All steel frame
- (1) One-piece green polyethylene cover
- (4) Protective corner boots
- 30 in. / 76,2 cm auger anchors
- Complete Hardware Kit
- Easy step-by-step instructions

Packaging Specifications:

- 4 boxes
- Total weight: 597 lbs. / 270,8 kg

Box 1:	61 x 21.9 x 9.6 in. 155 x 56 x 25 cm
Box 2:	61 x 21.9 x 4.9 in. 155 x 56 x 13 cm
Box 3:	52 x 19.5 x 7.7 in. 132 x 50 x 20 cm
Box 4:	42.5 x 19.1 x 6.7 in. 108 x 49 x 17 cm

